

# Dial Height Gages

SERIES 509

HEIGHT GAGES

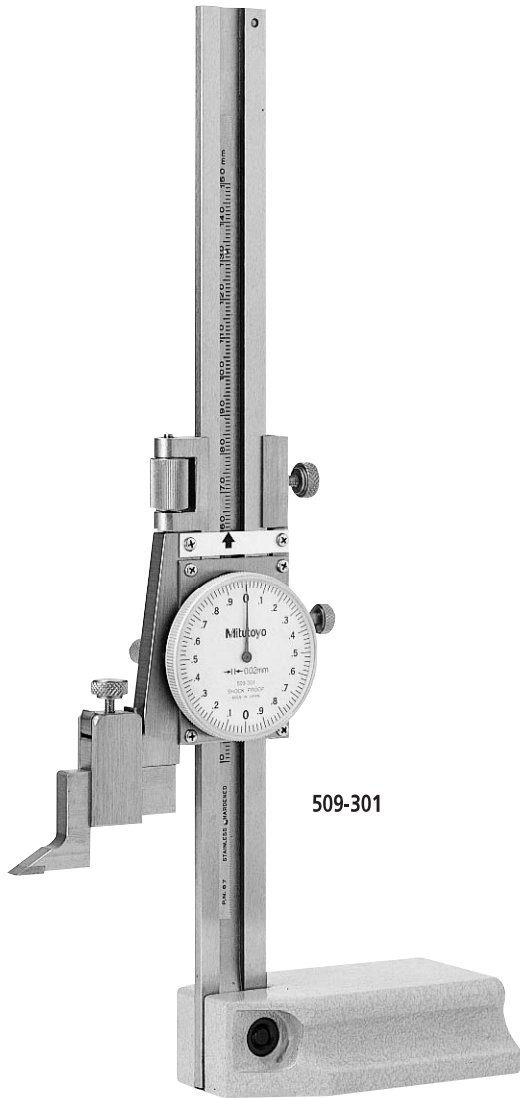

## FEATURES

- Easy and error-free reading with a dial.
- Made of stainless steel throughout.
- Provided with a carbide-tipped scriber (**900173**).

## Dimensions of Scriber

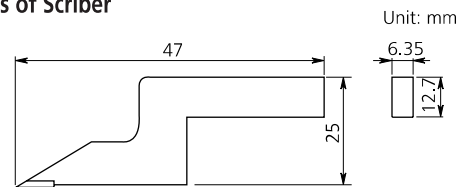

## SPECIFICATIONS

### Metric

Range	Order No.	Dial reading	Accuracy
0 - 150mm	<b>509-301</b>	0.02mm	±0.03mm
0 - 250mm	<b>509-302</b>	0.02mm	±0.04mm

### Inch

Range	Order No.	Dial reading	Accuracy
0 - 6"	<b>509-313</b>	.001"	±.001"
0 - 10"	<b>509-314</b>	.001"	±.0015"